



# DIRECTOR LODGING OPTIONS

---



706-262-8505



203 N. Lewis St. LaGrange, GA 30240



info@mscapescorp.com



## LODGING OPTIONS

*MSCAPES offers a range of thoughtfully designed accommodations that enhance the camp experience while supporting long-term operational needs. From compact leadership retreats to family-friendly cabins and premium canvas lodges, each solution is designed to provide durable, comfortable lodging that complements the natural character of camp while minimizing site disruption.*

*Available in a variety of configurations—including the NanoNomad, Nomad Two-Bedroom, Zanzibar Leadership Lodge, and A hard wall 12' x 16' Scout Tent—these accommodations support a wide range of uses, from camp leadership housing and staff lodging to volunteer retreats, donor hospitality, family camping, and guest accommodations. Each option balances functionality, comfort, and durability to meet the evolving needs of modern Scouting programs.*

*Whether positioned within a leadership village, overlooking a waterfront, nestled among mature pines, or integrated into existing campsite infrastructure, these lodging solutions provide flexible, scalable accommodations that strengthen camp operations, enhance guest experiences, and create welcoming spaces for those who lead, support, and participate in the Scouting mission.*

**NANOMAD**

**NOMAD  
2 BEDROOM**

**ZANZIBAR**

**1216 SCOUT  
TENT**



706-262-8505



203 N. Lewis St. LaGrange, GA 30240



info@mscapescorp.com



# NANOMAD - ON SKIDS



706-262-8505



203 N. Lewis St. LaGrange, GA 30240



info@mscapescorp.com



# NANOMAD - ON SKIDS

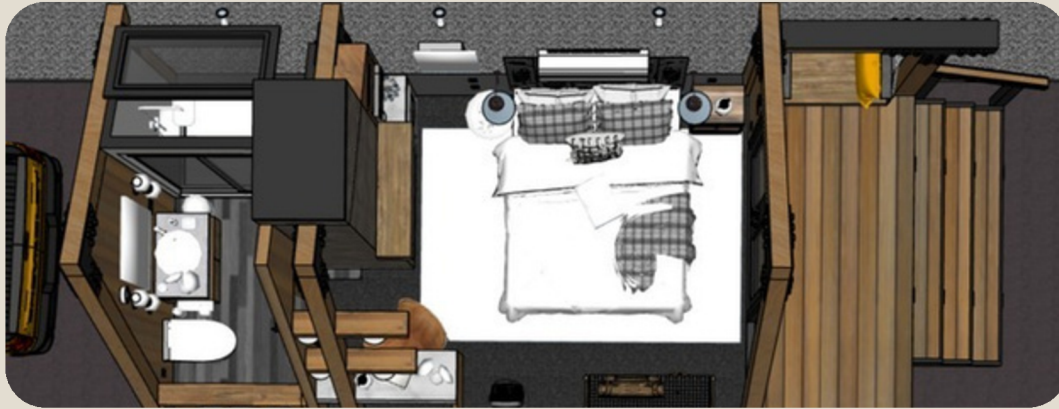

## SIDE VIEW ONE BEDROOM DIMENSIONS

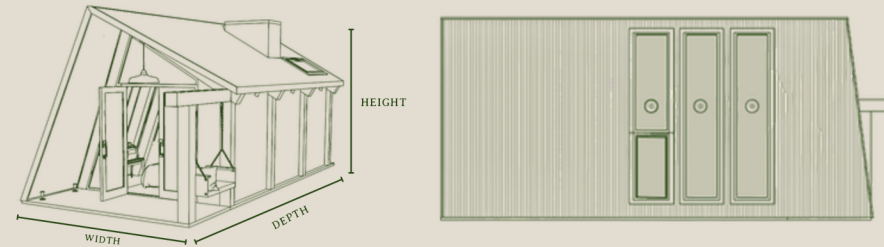

DEPTH: 11.5' | WIDTH: 24' | HEIGHT: 11.0' (13.5' WITH CHASSIS)

## WALLS INTERIOR & EXTERIOR

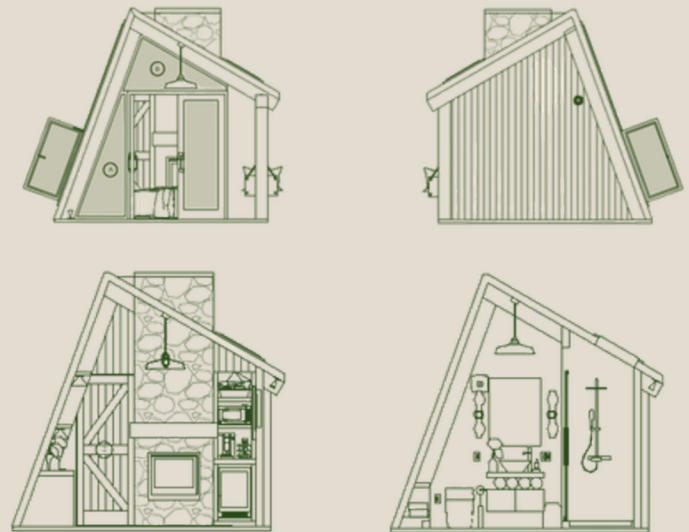

Designed to provide camp leadership with a comfortable and inspiring retreat experience, the Director Retreat Cabin blends the serenity of the outdoors with the conveniences of modern lodging. Constructed on a permanent skid foundation and fully assembled rather than a trailer frame, the cabin offers a durable, site-built appearance while maintaining flexibility for placement within the camp environment.

The structure features robust framing, weather-resistant materials, and expansive windows that maximize natural light and connection to the surrounding landscape. Thoughtfully designed interiors make efficient use of space, incorporating comfortable accommodations, quality finishes, and integrated building systems to support year-round use.

Built for longevity and low maintenance, the Director Retreat Cabin provides a turnkey solution for hosting camp directors, executive staff, donors, and special guests—creating a welcoming retreat that enhances the overall camp experience while supporting decades of reliable service.



706-262-8505



203 N. Lewis St. LaGrange, GA 30240



info@mscapescorp.com



# NOMAD (HARD SIDED) 2 BED:



706-262-8505



203 N. Lewis St. LaGrange, GA 30240



info@mscapescorp.com



# NOMAD (HARD SIDED) 2 BED:



## TWO BEDROOM DIMENSIONS

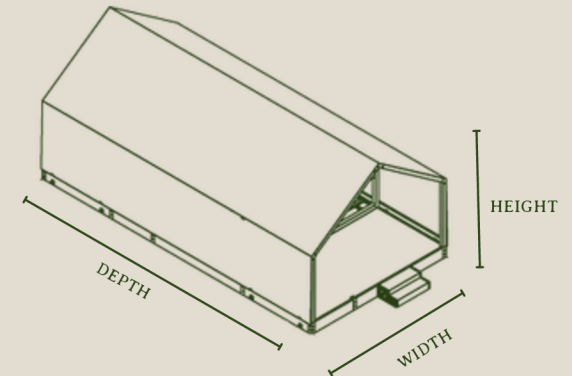

DEPTH: 35' | WIDTH: 14' | HEIGHT: 11'

## WALLS

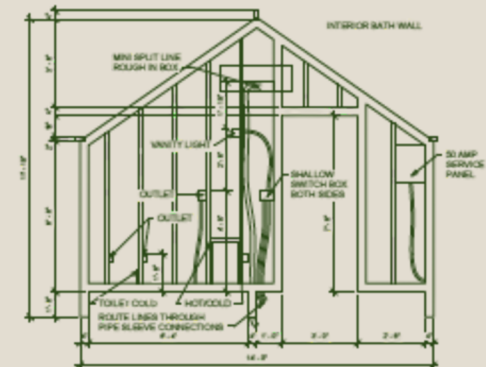
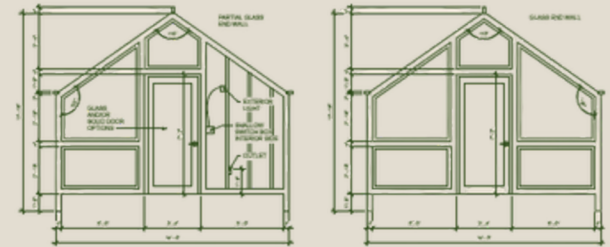

NOMAD reimagines the camp retreat experience, combining the natural beauty of the outdoors with thoughtfully integrated modern comforts. Designed as a semi-permanent leadership lodge, NOMAD provides a welcoming space for camp directors, executive staff, volunteers, donors, and special guests to recharge, collaborate, and connect with the mission of Scouting.

Available in one-bedroom, two-bedroom, and ADA-accessible configurations, NOMAD balances timeless architecture with practical functionality. Expansive windows frame the surrounding landscape, while durable construction, quality finishes, and efficient building systems ensure year-round comfort and reliability.

Whether nestled along a lakeshore, tucked within a wooded setting, or positioned near key camp amenities, NOMAD creates an elevated lodging experience that reflects the values of stewardship, hospitality, and adventure. Built for flexibility and long-term performance, it offers a turnkey retreat solution that enhances camp operations while providing a memorable and comfortable stay for camp leadership and distinguished guests.



706-262-8505



203 N. Lewis St. LaGrange, GA 30240



info@mscapescorp.com



# ZANZIBAR



706-262-8505



203 N. Lewis St. LaGrange, GA 30240



info@mscapescorp.com

ZANZIBAR redefines leadership lodging by combining the authenticity of canvas camping with the comfort, privacy, and functionality of a modern retreat. Purpose-built for camp directors, executive staff, volunteers, donors, and distinguished guests, Zanzibar provides a welcoming space to recharge, collaborate, and remain connected to the outdoor experience that defines Scouting. Its timeless design preserves the spirit of adventure while delivering the elevated accommodations today's camps increasingly seek for leadership and guest hospitality.

Inside, thoughtfully designed floor plans offer a balance of comfort and practicality, featuring private sleeping accommodations, dedicated living areas, climate-controlled interiors, modern bathrooms, and flexible layouts to accommodate a variety of camp needs. Expansive screened openings and large windows invite natural light and fresh air while maintaining a strong connection to the surrounding landscape, creating an environment that feels both refined and deeply rooted in nature.

Available in multiple configurations, Zanzibar delivers the durability, efficiency, and long-term performance camps require. Whether positioned along a waterfront, nestled within a wooded leadership village, or overlooking key camp amenities, Zanzibar provides a turnkey lodging solution that enhances camp operations, supports donor and VIP engagement, and offers a memorable stay for those who lead, support, and invest in the future of Scouting.





# SCOUT TENT (HARD SIDED) 1216



706-262-8505



203 N. Lewis St. LaGrange, GA 30240



info@mscapescorp.com